

IWS STRONG

GRAVITY PIPES

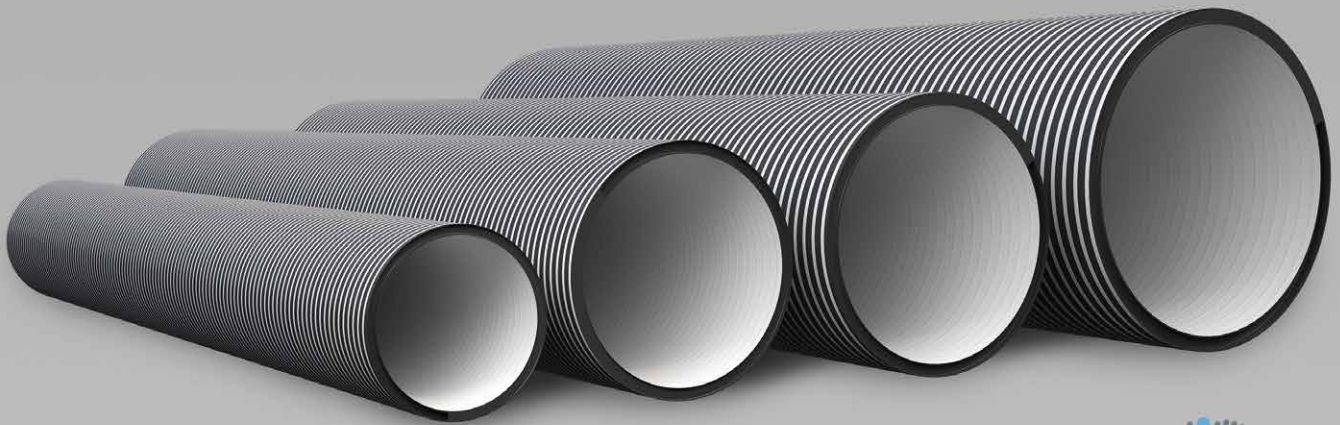

Nordic Poly Mark

Product range, p 4

Fields of application , p 6

Installation, p 9



100% reusable PE material



Resistant to Nordic climate



Safe to maintain



Resistant to mechanical damage



The PE material's guaranteed lifetime is 50 years



Dear customer!

Thank you for taking time to review our catalogue of gravity pipes!

Here you can find information about the fields of application, dimensions and installation of gravity pipes. Gravity pipes are certified according to Nordic standard INSTA SBC EN 13476 and labelled with Nordic Polymark label.

STRONG pipes are intended for the construction of culverts, stormwater and sewerage pipelines. STRONG pipes are also used for building manholes, pumping stations and tanks.

In addition to STRONG pipes, our product range includes manholes, pumping stations, tanks, septic tanks, etc. from the same brand.

More detailed information about our products can be found at www.iwsgroup.ee.

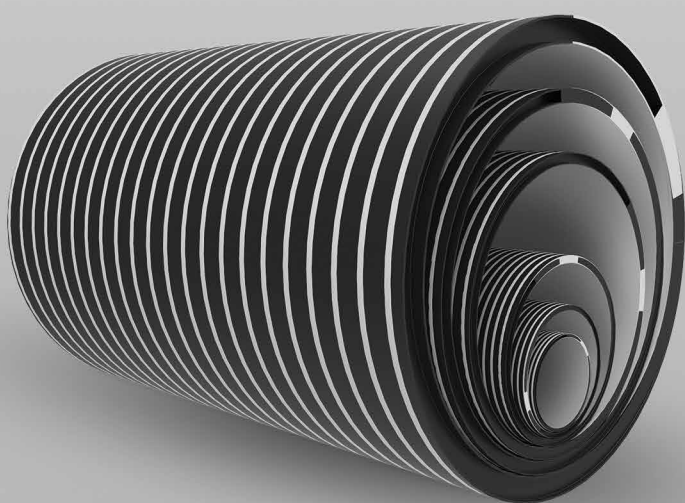

CONTENT

PRODUCT RANGE

4

CONNECTION
METHODS

6

FIELDS OF
APPLICATION

6

TECHNICAL
CHARACTERISTICS

7

INSTALLATION

9

RING STIFFNESS
CLASS

12

DEFORMATIONS

13

HYDRAULIC
CALCULATION

14

PRODUCT RANGE

GRAVITY PIPES

ID	Ring stiffness classes				Standard length
	mm	2 kN / m ²	4 kN / m ²	8 kN / m ²	
360	-	SN4	-	-	6
500	SN2	SN4	SN8	-	6
520	SN2	SN4	-	-	6
600	SN2	SN4	SN8	SN16	6
700	SN2	SN4	SN8	SN16	12
800	SN2	SN4	SN8	SN16	6
1000	SN2	SN4	SN8	SN16	12
1200	SN2	SN4	SN8	SN16	12
1250	SN2	SN4	SN8	SN16	12
1400	SN2	SN4	SN8	SN16	12
1500	SN2	SN4	SN8	SN16	12
1600	SN2	SN4	SN8	-	12
2000	SN2	SN4	-	-	12
2200	SN2	SN4	-	-	12
2400	SN2	SN4	-	-	12



ID - inner diameter

Up to 13.5 m long pipes are available by request.

BENDS

ID	From two segments	From three segments
	mm	
360	1-45°	46-90°
500	1-45°	46-90°
520	1-45°	46-90°
600	1-45°	46-90°
700	1-45°	46-90°
800	1-45°	46-90°
1000	1-45°	46-90°
1200	1-45°	46-90°
1250	1-45°	46-90°
1400	1-45°	46-90°
1500	1-45°	46-90°
1600	1-45°	46-90°
2000	1-45°	46-90°
2200	1-45°	46-90°
2400	1-45°	46-90°

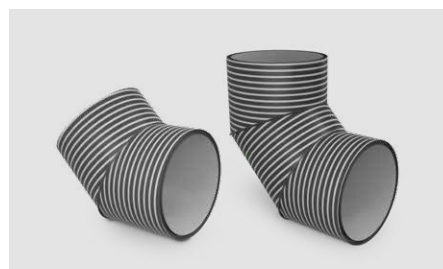

PRODUCT RANGE

MANHOLES

Pipe ID	Pipe ID / telescope pipe OD
mm	mm / mm
500	700-2400 / 500-630
600	800-2400 / 500-630
700	1000-2400 / 630
800	1000-2400 / 631
1000	1400-2400 / 630
1200	1400-2400 / 630
1250	1400-2400 / 630
1400	1600-2400 / 630
1500	2000-2400 / 630
1600	2000-2400 / 630
2000	2400 / 630



Manholes on gravity pipelines are designed in places where the flow direction or the pipeline drop changes, the pipeline begins, two or more pipelines join or the diameter of the pipeline changes. Also, at certain

distances for checking and maintaining long pipelines. The manholes are manufactured according to the heights and inlets and outlets as foreseen in the design.

The manholes are manufactured according to standard EVS-EN 13598-2:2016. The ring stiffness of the manhole housings is at least SN2 (2kN/m²) which is resistant to potential mechanical injuries during the installation or operation process.

SADDLE MANHOLES

Pipe ID	Saddle manhole housing ID / telescope pipe OD	
	mm / mm	mm / mm
1000	700 / 500	-
1200	700 / 500	1000 / 630
1250	700 / 500	1000 / 630
1400	700 / 500	1000 / 630
1500	700 / 500	1000 / 630
1600	700 / 500	1000 / 630
2000	700 / 500	1000 / 630
2200	700 / 500	1000 / 630
2400	700 / 500	1000 / 630

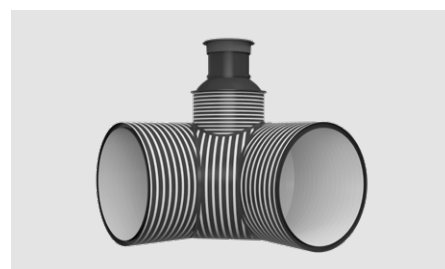

From pipeline diameter ID 1000 and up, it is advisable to use saddle manholes as turning and flow manholes.

CONNECTION METHODS

COUPLING



The most convenient and common pipe connection method is using a coupling. The coupling is made of a rubber



sleeve and stainless steel fixation and tensioning bands.



EXTRUSION WELDING



Another connection method is extrusion welding. The pipe joints of the connected pipes are welded together by extrusion welding.



Usually both the outer as well as the inner connection point of the pipes are welded together.



FIELDS OF APPLICATION



WASTEWATER AND STORMWATER SEWERAGE



CULVERTS



VENTILATION



MANHOLES



PUMPING STATIONS



TANKS

TECHNICAL CHARACTERISTICS

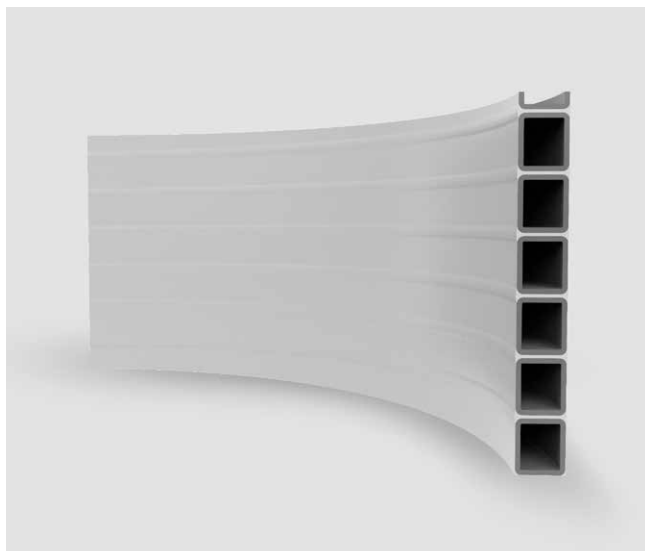

STANDARD

INSTA SBC EN 13476,
Nordic Polymark



MATERIAL AND COLOUR

Gravity pipes are manufactured of high-density polyethylene (HDPE).

The outer surface of the pipes is gray and black striped and the inner layer is gray.

PHYSICAL CHARACTERISTICS

CHARACTERISTIC	UNIT	SIZE	STANDARD
Density	g/cm ³	0,96	ASTM D1505
Melt flow rate (MFR)	g/10min	> 0,23	ISO 1133
Tensile module	Mpa	900	ASTM D638
Temperature resistance	°C	max +45	long-term
Temperature resistance	°C	max +80	short-term
Coefficient of thermal expansion	mm/m °C	0,18	

As a material, PE is elastic and with very good wear resistance.

Nowadays, PE is the main material for manufacturing manholes, tanks, pumping stations, water and sewerage pipes.

CHEMICAL RESISTANCE

STRONG pipes are intended for building sewerage, stormwater and industrial pipelines.

Under normal conditions of use, PE is chemically inert, the pipes manufactu-

red of PE do not rot, rust or corrode as the result of chemical reactions inside the ground, and no substances are released or dissolved into the environment from such pipes. Polyethylene is

resistant to most chemicals, however, in the case of hazardous liquids and chemically active substances, the suitability of PE needs to be additionally verified.

TECHNICAL CHARACTERISTICS

QUALITY CONTROL

The production of Innovative Water Systems Ltd is certified with ISO9001 quality management standard and ISO14001 environmental management standard.



STRONG PE pipes are manufactured and certified according to Nordic standard INSTA SBC EN 13476 and labelled with Nordic Polymark label.

• INSTA-CERT. •



The pipes are labelled according to the standard and the labelling includes:

- approval mark and standard number
- inner diameter ID (mm)
- manufacturer and trademark
- ring stiffness class (kN/m²)
- material
- area of application
- product code
- note about installation at up to -10 °C
- date of manufacture



According to standard INSTA SBC EN 13476, each batch of products shall be tested for ring stiffness.

The ring stiffness test is performed according to standard EVS-EN ISO 9969.



INSTALLATION

The pipes are installed based on guide RIL 77-2013 "Plastic pipes installed underground and into water. Installation guide." of the Finnish Association of Civil Engineers.

TRANSPORT, STORAGE AND LIFTING

The pipes are transported on a flat base with no sharp edges or other objects which may damage the pipe. To avoid the shifting of pipes, they must be properly fastened before transportation.

The pipes must be transported and stored in a way that the pipes would not be under constant deflection the radius of which would be under $50 \times ID$.

When using mechanical lifting devices, the equipment and the lifting slings may not damage the pipes. Use lifting straps to lift the pipes. If necessary, use the lifting jib. Steel ropes and chains may not be put around the pipe.



TRENCH

The dimensions of the cross-section of the trench and the shape are designed based on the dimensions of the pipes installed in the trench and the properties of the soil determined by geological surveys. Generally, the trench is as narrow as possible, considering the space needed for support structures and performing the works and properly compact the initial filling poured around the pipes. The minimum width of the bottom of a supported trench is 1.0 m and 1.2 m for an unsupported trench. Avoid making an unreasonably wide trench because it may weaken the side support the initial filling offers to the pipe.

If the soil characteristics allow, steps may be made in the trench in the places designated in the design.

The horizontal distance between the outer surfaces of adjacent pipes must be at least 200 mm. The pipe must be at least 400 mm from the trench wall. The distance between gravity sewerage pipes must be at least 300 mm. In the places where the manholes are installed, the trenches are expanded, so that the manhole would remain at least 400 mm from the trench wall. The vertical distance between the pipes must allow to make all the necessary pipe connections but may not be under 100 mm.

When determining the depth of the trench, it must be considered that if the soil is not suitable as an installation base, at least a 150 mm layer of levelling material must be put under the pipe. The bottom of the trench is excavated very carefully, so that the soil would remain as untouched as possible. If the soil is soft or easily impaired, unnecessary movement in the trench should be avoided.

If several pipelines are installed in the trench, measurements given on **figure 1** must be observed.

The inclination of the trench wall and its need for support is determined based on necessity or operational safety requirements. The inclination and the support are determined in the excavation part of the building design.

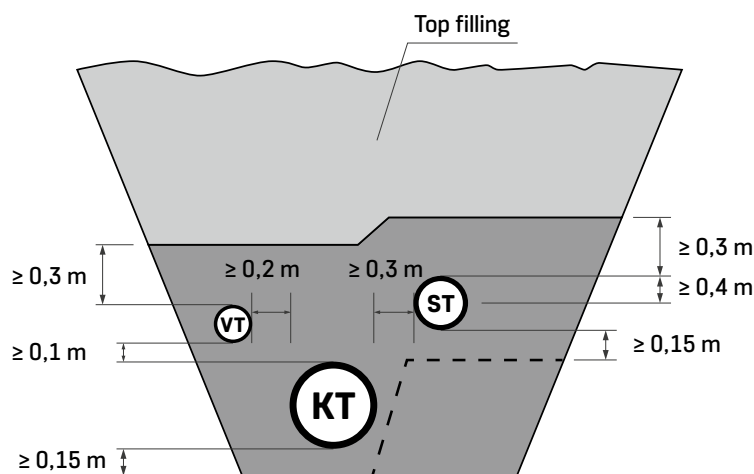

ST - gravity stormwater pipe
KT - gravity sewerage pipe
VT - water pressure pipe

Figure 1. Distances between pipes in trench

INSTALLATION

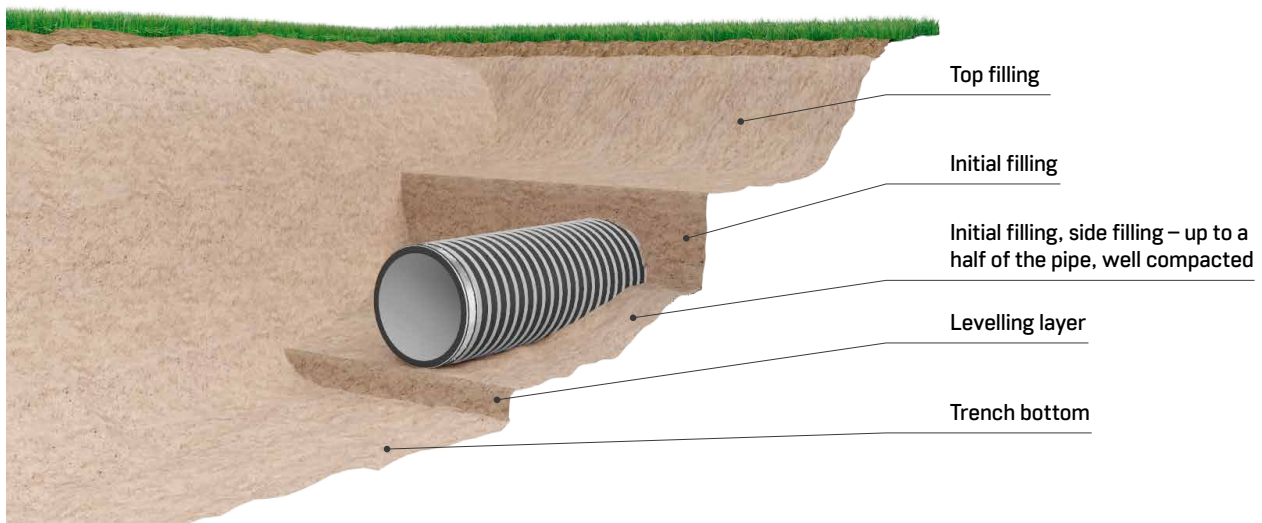

Figure 2. Trench

BUILDING A BASE

The trench bottom must be carefully evened and cleaned of rocks. Depending on the soil conditions, the trench bottom may need substructures for increasing the load bearing capacity of

the soil, i.e., avoiding the sinking of the pipeline.

More detailed information about the necessity of substructures and the recommended ways of establishing

them can be found from Chapter 4.3 SUBSTRUCTURES of RIL 77-2013. If a substructure is not needed, the pipes rest on either the base layer or directly on the soil in the way described in chapter LEVELLING LAYER.

LEVELLING LAYER

The trench bottom (the replaced soil or a base) is covered with a levelling layer, the thickness of which is at least 150 mm measured from the most lower surface of the wall of a straight pipe section. Unless otherwise indicated in the building design, in the traffic zone the levelling layer is always made of sand, gravel or crushed stones.

The maximum allowed grain size of the natural stones used for building the levelling layer is determined by the outer dimension of the used pipe.

When the outer diameter of a pipe is more than 600 mm, the maximum allowed grain size is always 60 mm. For smaller pipes, the grain sizes are provided in the guide RIL 77-2013.

If the soil is suitable for the levelling layer outside the traffic zone, no separate levelling layer is needed under the pipes. When installing the pipeline straight on the levelled trench bottom, the excavation works must be carried out extremely carefully, so that the installation base would be level enough.

Check that there would be no stones in the soil down to the depth of the levelling layer.

The soil and the material of the levelling layer may not be frozen.

The compaction factor (adjusted Proctor) must be at least 90% and if not otherwise provided in the design, the compaction must be mechanical. The compaction factor must be determined by measurement (PROCTOR method).

INSTALLATION OF PIPES

Before installing the pipes, the flawlessness of the pipes must be checked. After transporting and the possible processing of the pipes, the pipes must be thoroughly cleaned.

The pipes are placed on the levelled bottom of the trench or on a specific structure in a way that the pipe would be supported equally throughout its length.

Indents are made for couplings, so that the pipe would not rest on the couplings.

Pipes may not be installed on wooden blocks or any other similar structures.

If the temperature falls below -15 °C during the installation, the works must be carried on based on the special instructions by the manufacturer.

Follow the instructions of the manufacturer when supporting bends and joints.

The structure and execution of concrete supports must give the sufficient support for the pipe but not burden it. If the works are interrupted, the end of the pipe must be closed with a cap.

During the installation works, the water level in the trench must be kept so low that it would not damage or lift the pipe.

When installing the pipes in the area of a railway or a road, follow the instructions of the respective authorities.

INSTALLATION

INITIAL FILLING

Initial filling is the backfill material which is laid on the soil or levelling layer and around the pipe. The thickness of the initial filling must be at least 300 mm, measured from the ceiling of the pipe.

The initial filling must correspond to the same requirements as the levelling layer.

The initial filling material may not be poured on pipes in a way that they could get damaged or shift. The material must be poured to both sides of the pipe as evenly as possible and then pressed under the pipe and to the sides.

The first layer of the backfill may not extend more than halfway up the pipe.

In the first stage of work, the initial filling material is spread in the trench with a spade or in a similar way and then compacted, avoiding the shifting and damaging of the pipe that rests at the height foreseen in the design. In order to prevent the pipe from raising, put a weight on the pipe or anchor the pipe for the time of compacting works. If necessary, the pipe may also be filled with water for that time.

The initial filling of the trench is also installed and compacted as homogeneous layers in the longitudinal direction of the pipe.

The soil layer above the pipe is mechanically compacted only when it is at least 300 mm thick. For other compacting methods, this requirement is 150 mm. Figure 3 presents the recommended principles for making the initial filling as layers. The density of the initial filling (PROCTOR method) must be at least 90% unless otherwise provided in the design. The compaction must be verified with measurements.

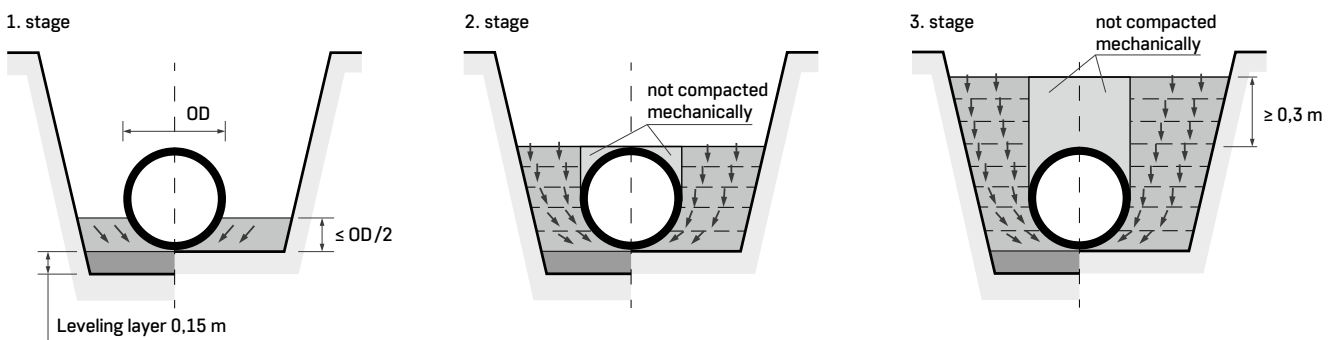

Figure 3. Installation of initial trench filling by layers.



Pay extra attention to compressing the filling supporting the lower side of the pipe.

TOP FILLING

In the traffic zone, the characteristics of the material of the top filling must allow it to be compressed. If the excavated soil can be compressed well, it may be used as the top filling. In other cases, a filling material with similar freezing properties is bought from elsewhere. The last backfill in the top structure layer must still be from the same material as the surrounding area.

In the one metre thick layer of top filling, measured from the top of the pipe, there may not be stones or chunks with the diameter of above 300 mm.

Stones in the top filling material may not be closer to the pipe than their own

diameter. The maximum permitted diameter of stones in the upper layer is $2/3$ of the thickness of the layer compacted at once. In order to avoid spaces in the filling, the material must consist of grains with different sizes.

Outside the traffic zone, the excavated soil is generally used as the top filling. The maximum permitted grain size is the same as in the traffic zone.

Unless otherwise provided in the design, the top filling must be compressed mechanically to the level of 90% (PROCTOR method) or according to the structure of the road surface.

Outside the traffic zone the top filling may not be compressed or it may be compressed to the density corresponding to local conditions. The trench must be filled to the level that the compressed filling would later sink to the level foreseen in the design or to the level of the surrounding ground.

The support structures of the trench will be demolished or removed, if it is possible without jeopardising operational safety or the stability of trench walls. The removal of support structures may not cause the sparsity of the already compressed filling or the shifting of the pipe.

SELECTION OF RING STIFFNESS CLASS

The selection of the ring stiffness class of gravity pipes is mainly influenced by the initial filling material poured around the pipes and its density as well as the thickness of the layer affecting the pipe, and the traffic load.

When building outside the traffic zone and under normal circumstances and if the initial filling is properly compressed and consists of sand, gravel or crushed stones, pipes with ring stiffness class

of at least SN 4 are used with a filling material thickness up to 6 m. If the thickness of the filling material is over 6 m, the ring stiffness class must be at least SN 8.

When determining the ring stiffness class of a gravity pipeline installed in a traffic zone (including the roads on the construction site), the traffic load affecting the pipe is also taken into

consideration besides the thickness of the filling material.

Pipes that are installed in a bearing protection structure that is not bound with the pipe may be installed based on a specific building design and with thinner filling layer than provided in table 1. However, the filling layer must be at least 0,4 m. If the thickness of the filling layer is over 6 metres, a detailed building and installation design must be prepared.

PURPOSE OF AREA	THICKNESS OF FILLING LAYER (m) FROM TOP OF PIPE	RING STIFFNESS CLASS
Cycle and pedestrian paths, calm traffic areas	0,8 - 6,0	SN2, ID1400 - 2000 mm
	0,8 - 6,0	SN4
	> 6,0	SN8
Streets, parking areas, storage sites	1,0 - 6,0	SN8
	> 6,0	SN16

Table 1. Selecting the ring stiffness class for plastic gravity pipes in the traffic zone.

DEFORMATIONS

A plastic pipe installed in the soil and the surrounding initial filling form an integrated whole, the behaviour of which is affected by the characteristics of both the pipe and the soil as well as their interaction (figure 4).

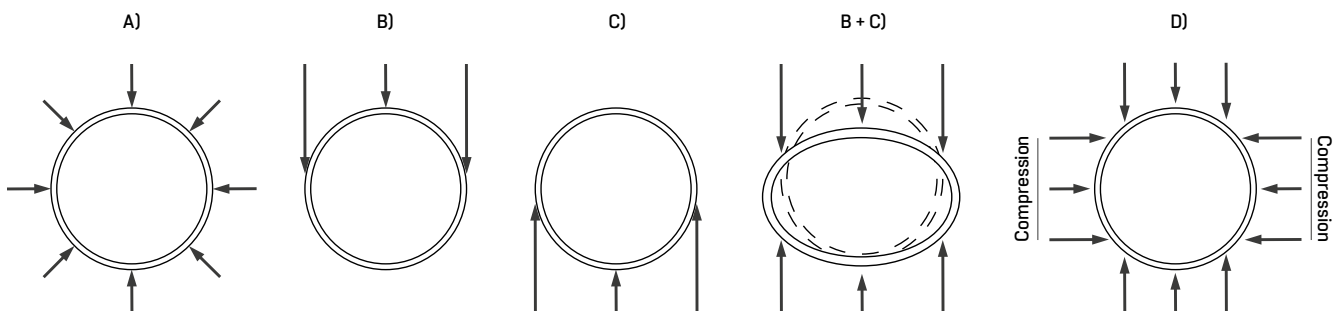

Figure 4. Behaviour of a plastic pipe in soil. Principal diagram.

DEFORMATIONS

If a pipe is installed in the soil lower than the level of groundwater, then the upward shove of the pipe due to groundwater and a strong reduction of the density of the soil below the

level of groundwater, especially when using fine-grained soil types as initial filling materials, may cause uneven load distribution on the pipe.

- The aim is to create a situation where the soil pressure and the groundwater pressure around the pipe distribute evenly **(A)**.
- The trench backfill on the pipe causes load on the upper surface of the pipe **(B)**.
- Maintaining the required subsurface causes a load affecting the lower part of the pipe **(C)**.
- If there is insufficient load affecting the sides of the pipe, the ring stiffness of the pipe is not sufficient for avoiding the compression of the pipe **(B+C)**.
- To avoid situation B+C, the initial filling on both sides of the pipe must be properly compressed into a homogenous surface **(D)**.

If the load directed to the plastic pipe is uniform throughout the perimeter of the pipe, the pipe retains its original round form.

When designing and installing plastic pipelines, the fact that the initial filling below and around the pipe is not always possible to compress into a completely homogeneous surface is always taken into consideration. An initially uniform load may become uneven over time and then the pipe may become deformed due to the uneven load on the surface of the pipe. Deformation may increase until the vertical and horizontal forces affecting the pipe achieve balance.

In order to ensure a long-term service life of the pipeline, the installation process together with the initial filling must be made in a way that the deformation after the installation, caused by uneven density, would be as small as possible.

When installing and compressing the initial filling, it is expedient to set a limit value for the deformation of the pipe after installation.

The maximum permitted post-installation of PE pipes is 8%. Post-installation means 2 to 3 weeks from the moment of installation.

The limit value of the permitted deformation is determined by the fact that upon following the pipe installation

instructions, the pipe deformation would not exceed 15% during the service life of the pipeline (50 years).

If the deformation values measured during the inspection carried out during the handover of the piping works exceed the permitted results, the causes for creating such a situation must be determined. The reason usually lies in the reckless installation of the initial filling. Based on the measurement results and the determined causes, it is decided whether the monitoring of deformation is continued and based on which schedule. The surveys of plastic pipes have indicated that if the exterior load situation remains unchanged, the pipe achieves stability and the deformation becomes to a halt in 1 to 2 years after the installation.

MANHOLE COVER STRENGTH CLASSES. EVS-EN 124.

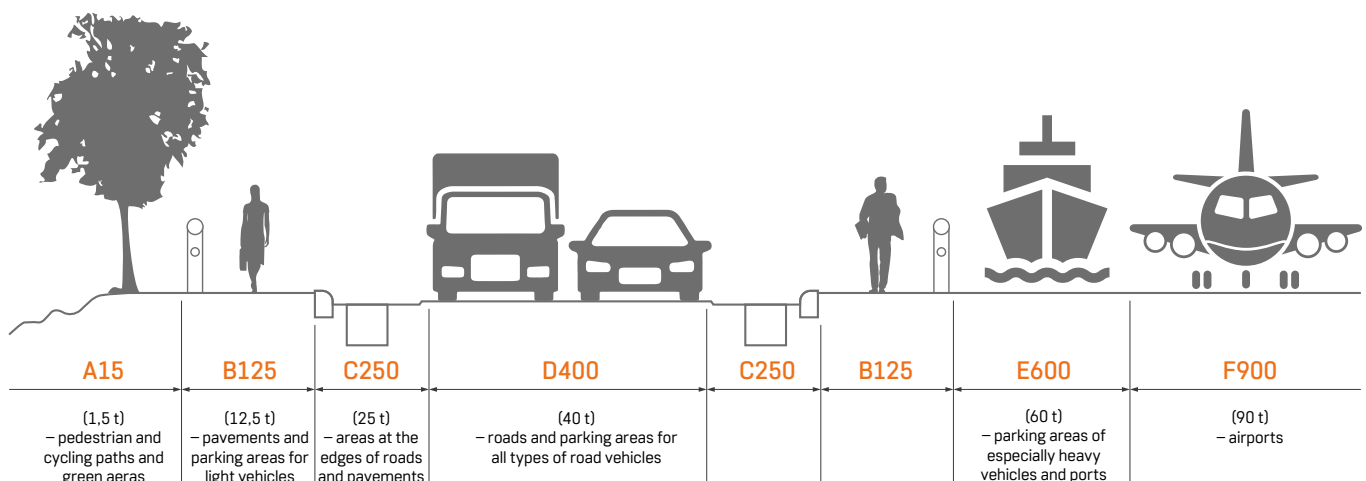

HYDRAULIC CALCULATION

PARTIALLY FILLED GRAVITY PIPES

Gravity pipes are covered free flow beds which mostly operate with partial filling. The peculiarity of round cross section is that if a relative filling h/d exceeds a certain value (0.813), the hydraulic radius starts to decrease and the maximum capacity of the pipeline is achieved when the pipe is not completely full yet. The values characterising round cross section, depending on the filling, can be found from the following diagram. It can be seen that the flow rate is largest at $h/d = 0.813$ and at capacity $h/d = 0.95$. The recommended calculated pipe fill level is $h/d \approx 0,7$

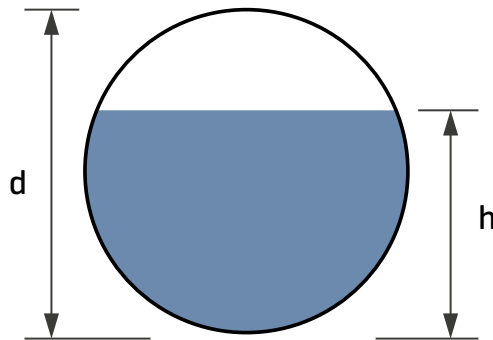

- Q** – relative volumetric flow rate
- V** – relative flow rate
- R** – relative hydraulic radius
- h/d** – relative filling mm/mm

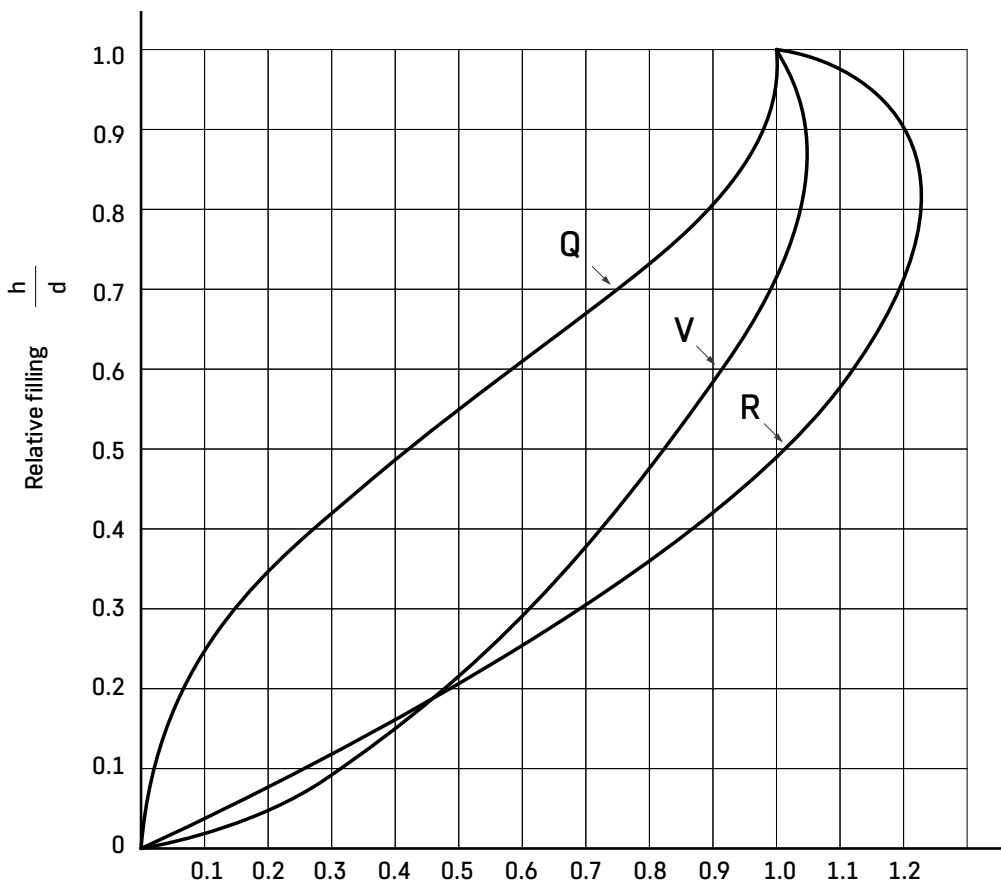

Diagram for calculating round cross section gravity pipelines with partial filling.

HYDRAULIC CALCULATION

CAPACITY OF GRAVITY PIPES WITH COMPLETE FILLING

The pipe roughness coefficient in the nomogram is 0.25 ($k=0.25$ mm). The actual value is certainly lower.

The pipe diameter is chosen based on the fact that the pipeline must be able to direct away the maximum amount of water. Additionally, even when the water amount is at its minimum, the

pipeline must be able to clean itself once in 24 hours.

In gravity pipes, gravity causes water to flow. For this, the pipeline is given a suitable declination depending on the cross section of the pipe. Water flow rate must be sufficient enough to remove all potential solid particles from the pipes.

The self-cleaning properties are generally ensured if the flow rate is at least ≥ 0.7 m/s once in 24 hours or if the declination of the pipeline is at least 1:ID. Nomograms are calculated based on inner diameters and for complete filling $h/d = 1$.

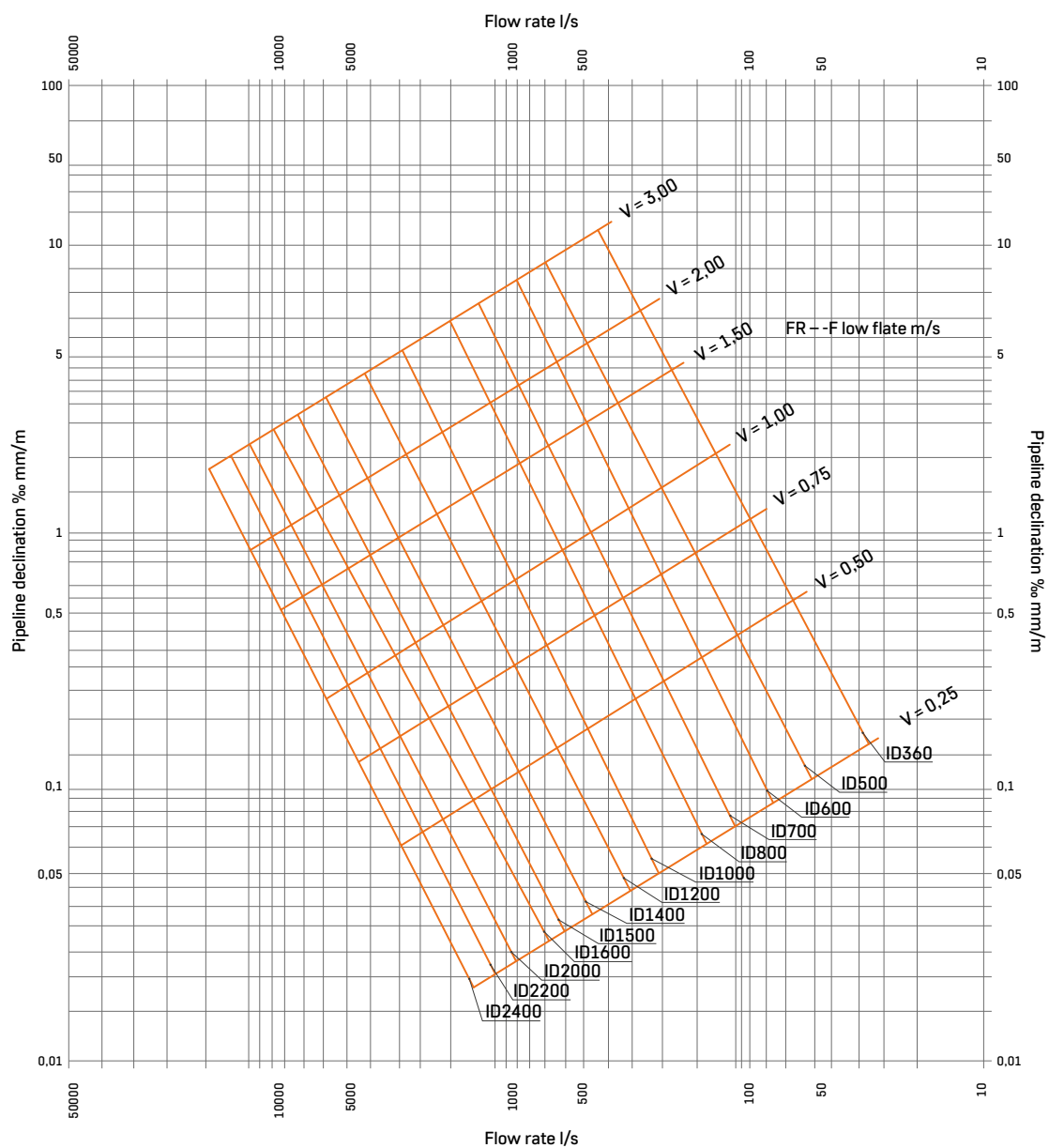

Nomogram for calculating gravity pipelines with complete filling.

