

Pos.	Description	Material, Type	Size
1	Cover	PE / Cast iron	according to selection
2	Handrail, telescopic, HAILO	AISI316	270x1620
3	Service opening	PE	according to selection
4	Ladder, non slippery steps, HAILO	AISI316	300x340
5	Air release valve	Steel	according to selection
6	Tank cylinder, double wall	PE100	ID1400, SN4
7	Ball valve / Gate valve AVK	AISI316 / Ductile iron	according to selection
8	Pressure pipe	PE100	according to selection
9	Bottom	PE/Concrete	155 mm
10	Backing rings	PP-Steel	according to selection
11	Bolts, nuts, washers	AISI316	M16

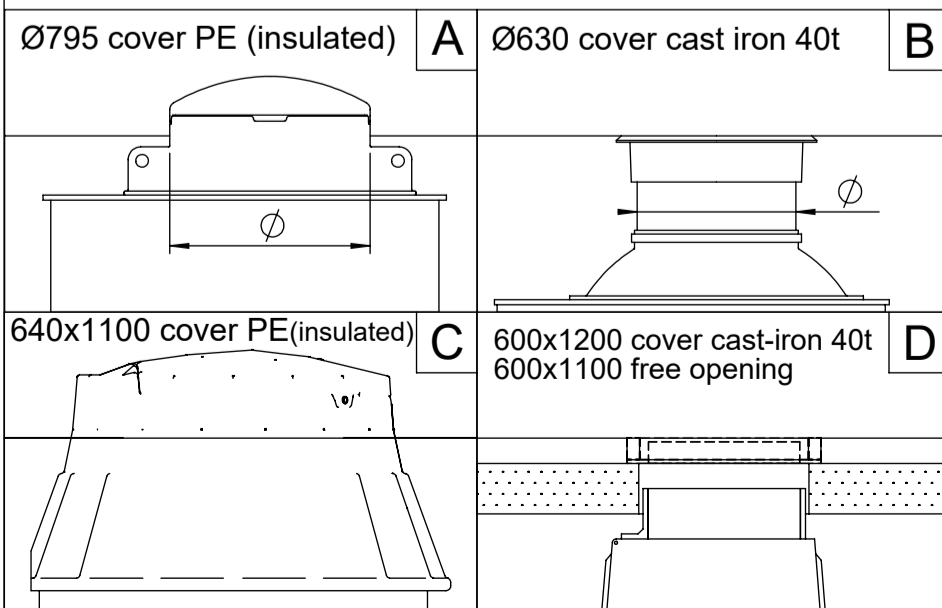

Service opening type	A <input type="checkbox"/> B <input type="checkbox"/> C <input type="checkbox"/> D <input type="checkbox"/>
Handrail, telescopic (not available for type "B")	<input type="checkbox"/> YES / NO <input type="checkbox"/>
Pressure pipe depth from Ground Surface	H =mm
Pressure pipe diameter	D =mm
Air release valve type	Potable water <input type="checkbox"/> Sewage
Air release valve connection	1" <input type="checkbox"/> 2" <input type="checkbox"/> DN50 <input type="checkbox"/> DN80 <input type="checkbox"/> DN100 <input type="checkbox"/>

Drawn:	E.Ehala	Air release well ID1400 STRONG		
Approved:	J.Karolin			
www.iwsgroup.ee		Mass: kg	Product code:	Rev.
Innovative Water Systems		NA	505215 / ordersheet	1