

PUMPING STATIONS

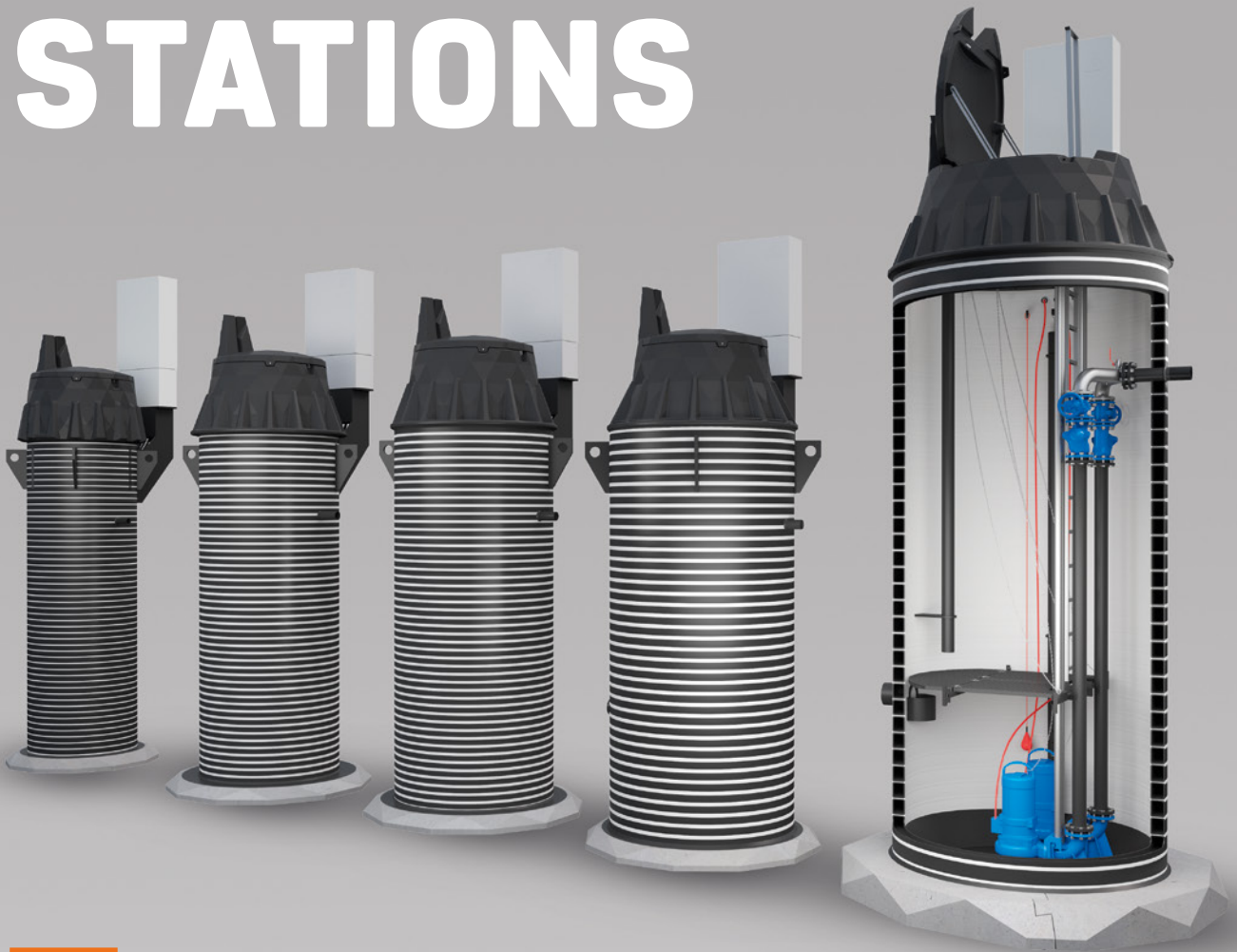

Product Range, pg. 4
Installation, pg. 7
Maintenance, pg. 13

CE
EN 12050 - 1



100% reusable PE material



Resistant to Nordic climate



Safe to maintain



Resistant to mechanical damage



The PE material's guaranteed lifetime is 50 years

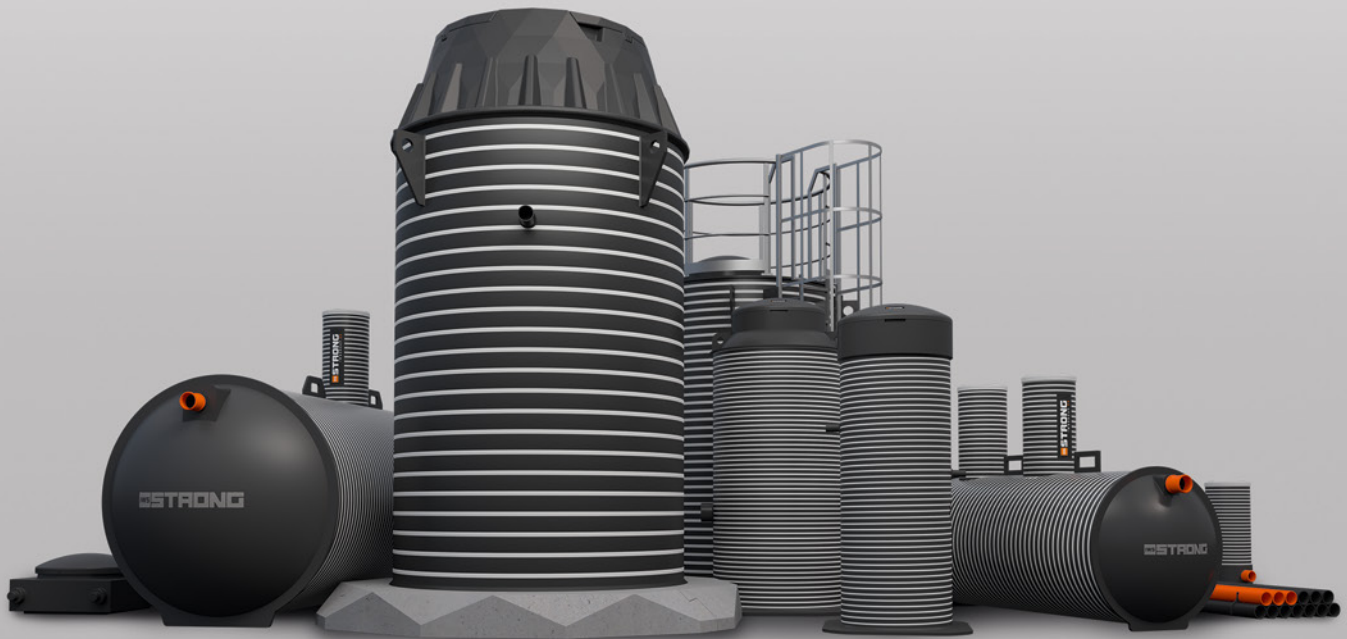

Dear customer!

Thank you for taking time review our pumping stations catalogue!

Here you will find information about the technical characteristics and installation of the pumping stations, as well as maintenance and safety advice.

Our pumping station development process focuses mainly on long-term durability, ease of installation and safety of use.

STRONG pumping stations are intended for pumping wastewater, stormwater and drainage water in places where it is impossible or unfeasible to construct gravity-flow piping. Even the most hard-to-please customer will find a suitable pumping station, pumps and control cabinet from us.

In addition to STRONG pumping stations, our product range includes also pumping stations with submersible pumps, booster pumping stations, tanks, septic tanks and other products of the same brand.

Detailed information about all our products is available at the address www.iwsgroup.ee/en.



CONTENT

PRODUCT RANGE

4

TECHNICAL CHARACTERISTICS

5

INSTALLATION

7

OPERATION

12

MAINTENANCE

13

WARRANTY

14

PRODUCT SELECTION

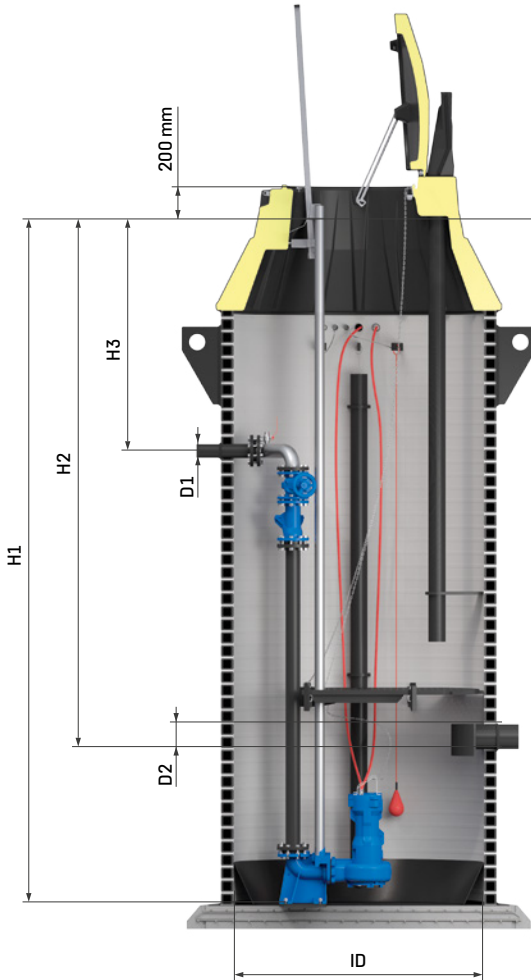

STRONG pumping stations are intended for pumping wastewater, stormwater and drainage water in places where it is impossible or unfeasible to construct gravity-flow piping.

STRONG pumping stations are single-chamber pumping stations with submersible pumps. The pumping stations are compact and consist of a collection tank, pumps, their lifting elements, pressure pipes and complete control cabinet.

As a rule, a pumping station uses two submersible pumps, so the pumping station remains operational even during maintenance or breakdown of one pump. The pumps work alternately, in extreme situations also simultaneously. The pumps are controlled by automatics installed to the pumping station's control cabinet. Level sensor or float switches are used for setting the pumping station's water levels for starting and stopping the pumps. The pumping station's control cabinet board is designed according to the customer's needs.

The pumping station's internal pressure piping is chosen according to the pump's auto-coupling size. A closing device should be installed to the pumping station's inlet pipe, so that the inflow can be shut off during maintenance works. This can be a knife gate valve inside the pumping station or an outside rubber gate valve.

Main input parameters for the pumping station:

- type of water to be pumped (wastewater, stormwater, etc.);
- pump parameters – flow rate (Q, l/s) and head (H, mVs);
- pumping station's internal diameter (ID, mm);
- pumping station's height from the ground (H1, mm);
- outflow pressure pipe's height (H3, mm) and diameter (D1, mm);
- inflow pipe's height (H2, mm) and diameter (D2, mm).

Diameter: ID1200
Pressure pipes: DN40-65



Diameter: ID1400
Pressure pipes: DN50-80



Diameter: ID1500
Pressure pipes: DN50-80



Diameter: ID1600
Pressure pipes: DN50-100



Diameter: ID2000
Pressure pipes: DN50-150



TECHNICAL CHARACTERISTICS

STRONG pumping stations are made of PE-HD (high-density polyethylene), which is an elastic and durable type of plastic. Nowadays, PE is a common material used for manufacturing pumping stations, tanks, wells and pressure pipes, because it is particularly durable in Nordic climate. The tank cylinder of STRONG pumping stations (ID1200–2000 mm) are strong, made with ring stiffness of at least SN4 (4 kN/m²), so they resist mechanical damage that may occur when installing or using the system. This is important for preventing wastewater leakage into soil or soil water penetration into the pumping station.



STRONG pumping stations are certified according to the European Union pumping stations standard EN 12050-1 and marked with the CE mark.

Cover: PE, 50 mm of thermal isolation



Service opening: PE, 50 mm of thermal isolation



Tank cylinder: PE100, SN4, EN 13476, Nordic Polymark



Anchoring bottom: PE100 / reinforced concrete C35/45 XC2

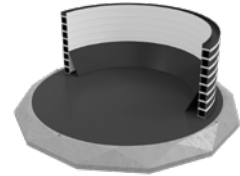

Handrail: A4, telescopic, EN 14396



Ladder: A4, non-slippery, EN 14396



Platform: PE100/A4, two-way opening



Base of control cabinet: PE100, cable protection pipes



TECHNICAL CHARACTERISTICS

1. Cover (PE or Al or A2, 50 mm thermal insulation)
2. Handrail (A4, two-sided and telescopic)
3. Service opening (PE, 50 mm of thermal insulation)
4. Pump guide rails (A4)
5. Ladder (A4, non-slippery steps)
6. Ventilation pipe (PE, vandal-proof)
7. Tank cylinder (PE100, double wall, ring stiffness SN4)
8. Pressure pipe tee (A4, 120°)
9. Rubber gate valve (GGG50, epoxide coating)
10. Check valve (GGG40, epoxide coating, NBR ball)
11. Pressure pipe (A4 or PE100 SDR17)
12. Service platform (PE100 or A4)
13. Sediments guide (PE100)
14. Auto-coupling (GG25, epoxide coating)
15. Bottom (PE100 / reinforced concrete min C35/45 XC2)

Free flanges

Bolts, nuts, washers (A4)

Lift chains (A4)

Gaskets (EPDM or NBR)

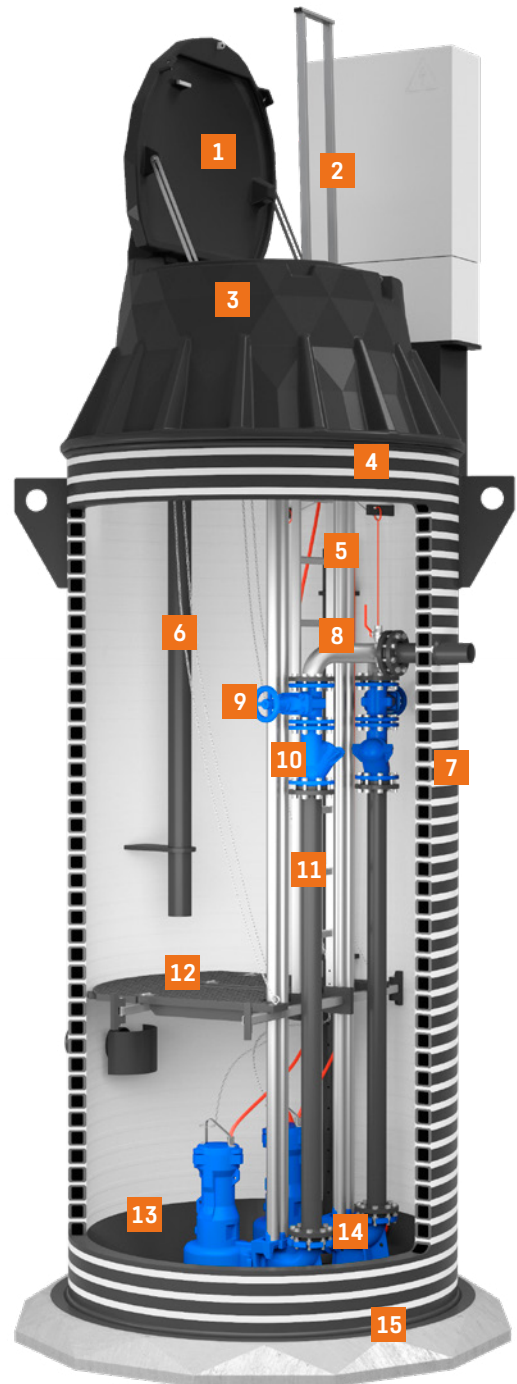

ACCESSORIES:

Flowmeter:
cast iron, inductive

Closing device on inlet:
cast iron, knife gate valve

Cast iron cover: DN900, 40T, for
ID1200-1600 pumping stations

Cast iron cover: 1300x700, 40T,
for ID2000 pumping station

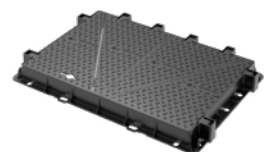

INSTALLATION

LIFTING OF PUMPING STATIONS

Use lift belts to lift a pumping station. If necessary, use a spreader bar. It is important to make sure that the lift belts do not damage any protruding parts. Do not put steel cables or chains around the pumping station. Use all available lift eyes and hanging lead ropes when lifting a pumping station into a trench.



When lifting the pumping station in a horizontal position, the weight of the concrete base plate 1.5T and due to the location of the center of gravity must be taken into account.

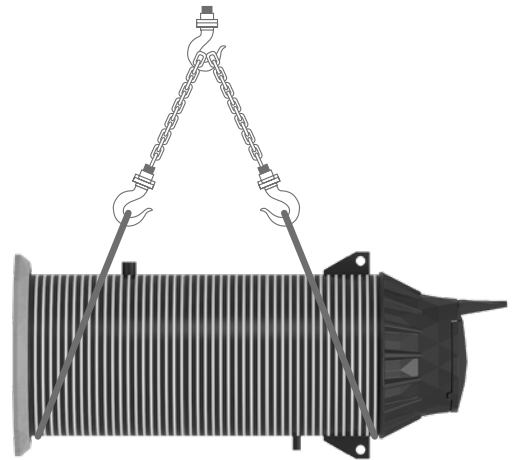

REQUIREMENTS FOR THE FILLING MATERIAL

Sand, gravel, and crushed stone are suitable filler materials. The filler must be clean, freely flowing, and must not contain ice, snow, clay, organic substances, or too large or heavy objects that may damage pumping station when falling onto it. Minimum required bulk density is 1,500 kg/m³.

Gravel

Gravel particle size must not be less than 3 mm or more than 20 mm.

Crushed stone

Crushed stone particle size must not be less than 3 mm or more than 16 mm.

Sand

The particle size must not exceed 3 mm.

Sand/gravel mixtures

Sand and gravel mixtures can be used if the components comply with the above requirements for gravel, crushed stone, and sand. Sand and gravel mixtures must be compacted as instructed below.

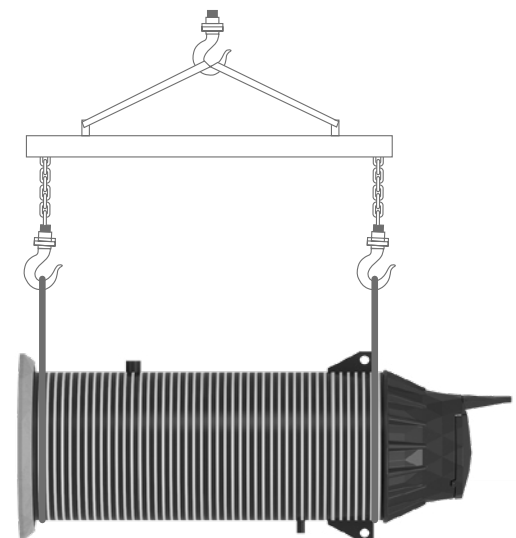

INSTALLATION

ANCHORING

Lifting force of groundwater

In order to neutralise the lifting force of groundwater and to ensure that the pumping station remains securely in place, the pumping station must be anchored. The anchoring base plate weight plus the pumping station's weight and the weight of the soil on the base plate edges extending beyond the pumping station's edges must be at least equal to the lifting force. Friction between the pumping station's outer wall and the soil is usually not taken into account (it is left as a reserve). Calculated counterweight depends on maximum groundwater level (the safest bet is to consider groundwater

level up to the ground surface as the maximum level) and the weight of an empty pumping station. Then the lifting force equals to the pumping station's volume.

Concrete anchoring base plate

Reinforced concrete anchoring plates have already been added to the STRONG pumping stations ID1200, ID1400, 1500 and 1600 mm in production. A reinforced concrete anchor plate is added to the ID2000 pumping station during production, to which three reinforced concrete anchor parts must be added in the trench. The dimensions and reinforcement of the anchoring plate are designed taking into account that the pumping station,

if properly installed, remains firmly in the ground to the maximum possible extent at groundwater level. The pumping station with anchoring plate is installed at a horizontal thickness of 300 mm from the standard density on mechanically compacted sand, gravel or crushed stone foundations to at least 95%. If soil conditions require so, sulphate-resistant concrete must be used. The need to change the environmental class of concrete must be notified and the conditions agreed before ordering the pumping station.

Concrete anchoring plate data:

Concrete class: C35/45
Environmental class: XC2

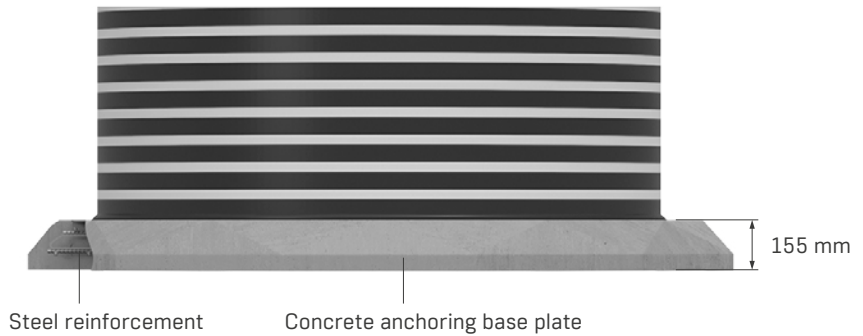

The bottom of the ID1200 pumping station

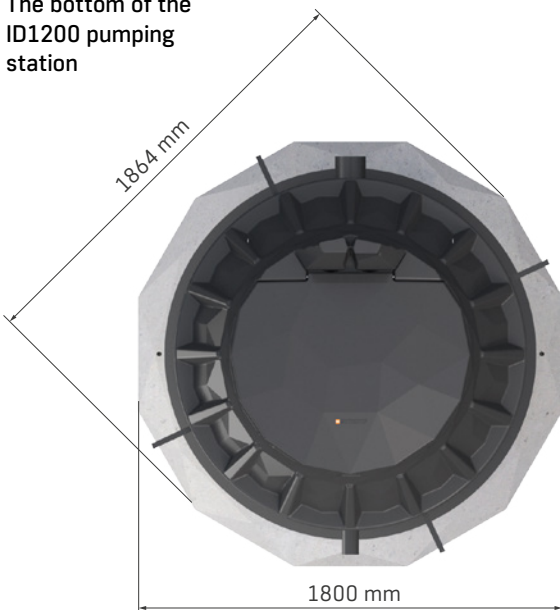

The bottom of the ID1400, 1500 and 1600 pumping stations

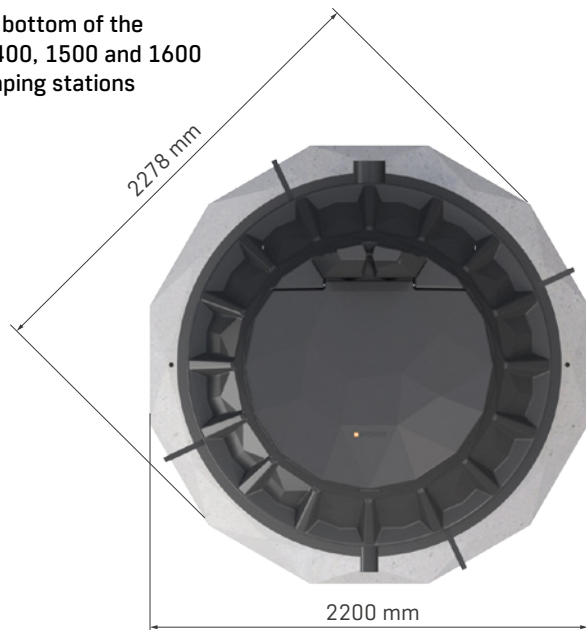

ID2000 pumping station bottom and anchoring parts

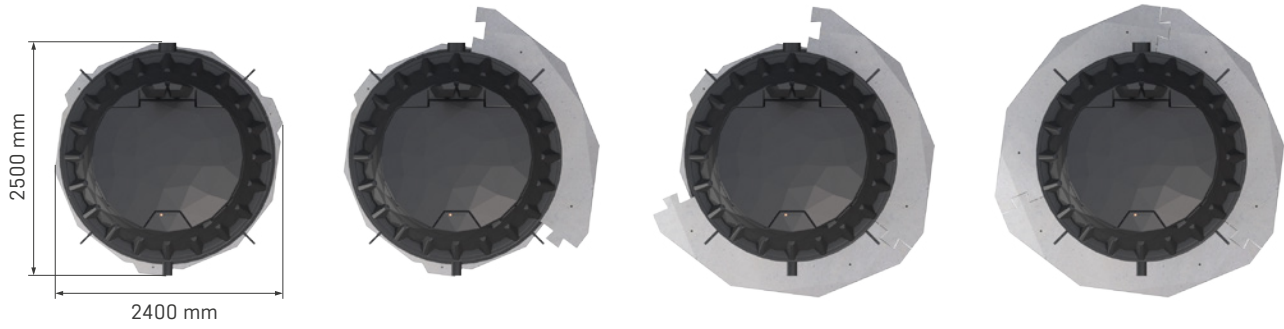

Installation of the anchoring parts of the ID2000 pumping station

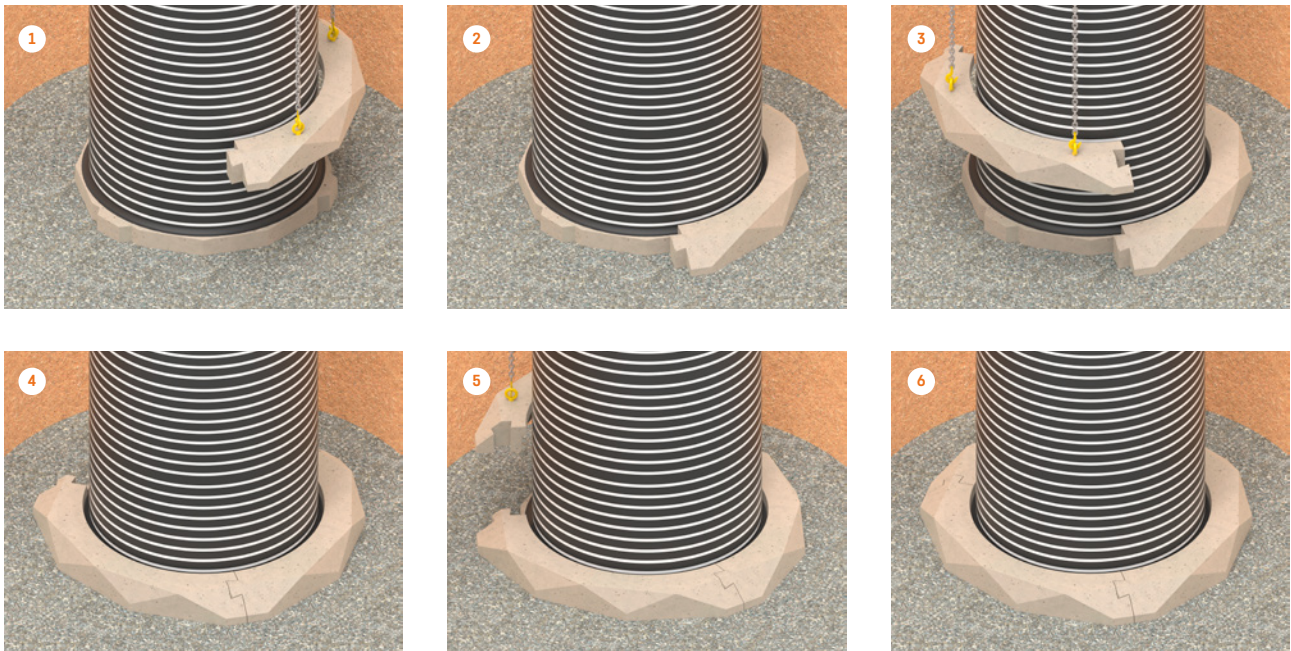

INSTALLATION

BACKFILLING

The pumping station trench is filled on all sides in 300 mm thick layers of gravel, crushed stone or sand, compacting each layer to 95% of the soil's natural density.

In case of high groundwater level or otherwise wet and heavy soil (e.g. clay soil), use only gravel or crushed stone as backfill material. During backfill works, keep the pumping station filled with water to the level of the current backfill layer. Take special care when compacting near the pumping station's pipe connections to avoid any empty spaces remaining there.

When installing the pumping station to a green area, make sure the cover reaches at least 100 mm above the ground, preferably even 200 mm, in order to prevent stormwater from entering the pumping station.

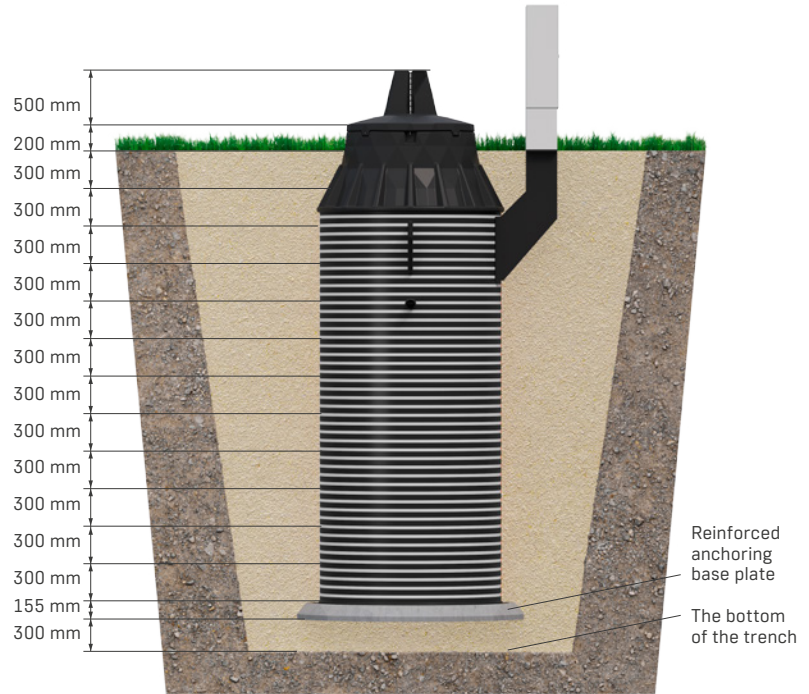

A pumping station installed without full backfilled topsoil layer may shift due to the impact of groundwater. Therefore, in the event of interruptions in trench filling, it must be ensured that groundwater does not enter the trench or fill the pumping station with water!

INSTALLATION UNDER TRAFFIC AREA

To avoid traffic load on a pumping station installed under traffic area, the pumping station must be covered by a 150 mm thick reinforced concrete load balancing plate. The plate must extend at least 500 mm beyond the pumping station in all directions. The cover must be selected for the corresponding traffic load class (A15 to F900), the standard selection is D400 (40 T). The cover must rest on a reinforced concrete load balancing plate to avoid the load from being transferred to the pumping station.

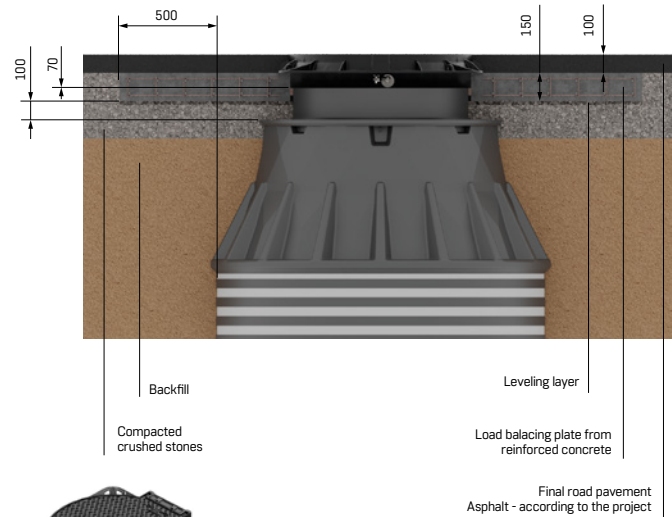

Reinforced concrete load balancing plate shall not remain lie to the service opening of pumping station.

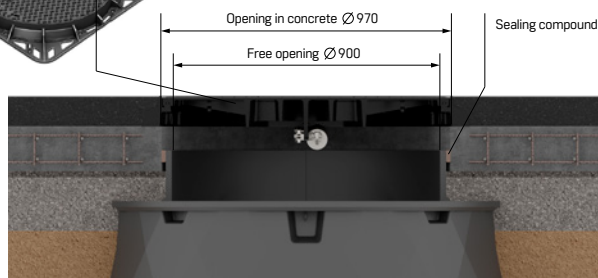

INSTALLATION OF DN900 CAST IRON COVERS IN AREA WITH TRAFFIC LOAD



1 Trench compacted with backfill material.

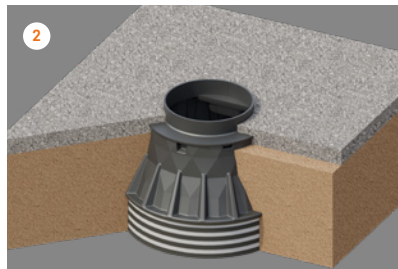

2 Add a layer of compacted crushed stone.

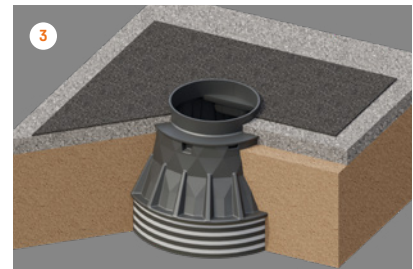

3 Install a leveling layer.

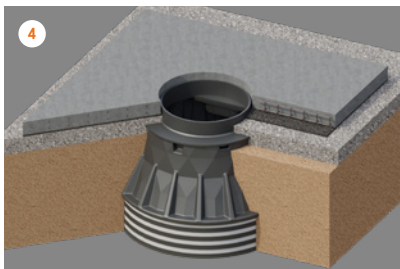

4 Add load balancing plate from reinforced concrete.

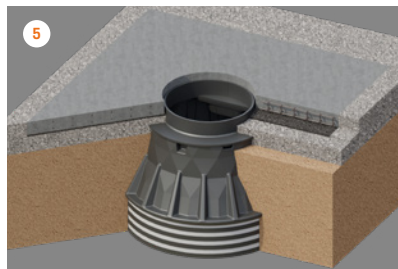

5 Add a layer of crushed stone around the load balancing plate.

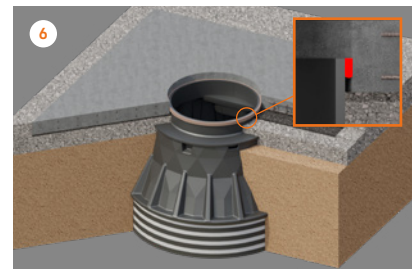

6 Install the sealing compound between the reinforced concrete plate and the service opening of the pumping station.

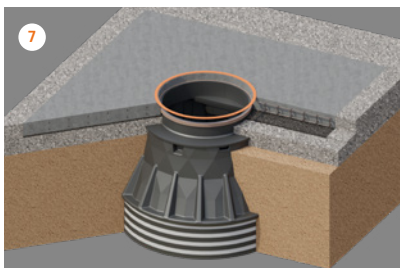

7 Install the sealing compound on top of the reinforced concrete plate (under the cast iron cover).



8 Install the cast iron cover.



9 During installation, check the opening direction of the cast iron cover in relation to the service ladder.



10 Fasten the cast iron cover at the corners with anchors bolts.

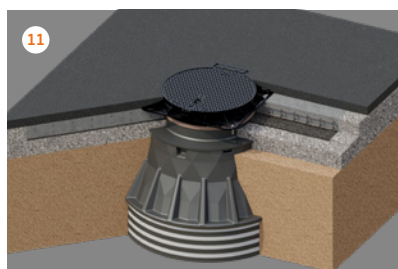

11 Install the final road pavement.

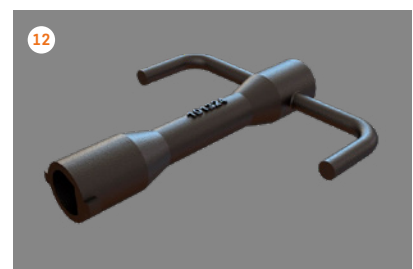

12 Cast iron cover key - OTCI.

OPERATION

The pumping station is intended for collecting and pumping wastewater or stormwater. As a rule, the pumping stations have two pumps, rarely one or three pumps. The pumps are controlled by automatics installed to the pumping station's control cabinet. Level sensor or float switches are used for setting the pumping station's water levels for starting and stopping the pumps. Read more about the controlling and monitoring of pumps in the automation instructions.



It is prohibited to lift the pump by its power cable.

If the pumping station is not used in winter then the pumping station and its internal piping must be drained of water to prevent it from freezing. To drain the internal piping, open the cover of check valves and let the pressure pipe drain.

STARTING THE PUMPS

1. Before starting the pumps, make sure the valves on pipes located in the pumping station and in outlet are open.
2. When setting the pumping station's water levels, make sure that the pump switches off at the water level required by its manufacturer. The minimum water levels are stated in the pumps' instructions. The water level must never drop below the chamber level of the impeller.

INSTALLATION AND DISMOUNTING OF PUMPS

Opening and closing the pumping station's cover

Plastic or aluminium cover are opened by first turning their fastening bolts counter-clockwise. Use the key delivered with the pumping station. The cover can be fixed to open position at 90°. To close the cover, set it back to its initial position and turn the locking bolts clockwise, using the same key.

Cast iron cover are opened by using a metal rod, inserting it into the cover's hole and lifting the cover up.



Before starting the pumps for the first time, inside pressure pipes bolted connections in pumping station should be checked and over tighten if necessary.

3. For pumps with a 3-phaser motor, check the rotor's rotation direction before starting the pump! As a rule, the rotation direction is marked on the pump's casing. If the pump rotates in wrong direction, the order of connecting the phases is wrong. To change that, order the phase wires around. Please be careful to avoid injury when checking the rotation.

Opening the service platform

The platform's opening part has stainless steel lift chains. The platform must be opened by using the lift chains before installing or dismantling the pumps.

Installing the pumps

The guide horn attached to the pump must be placed onto the guide rails and then the pump must be lowered along the rails onto its auto-coupling foot. To lift the pumps, use the prescribed stainless steel lift chains. The pump's correct positioning on its auto-coupling foot can be verified by starting the pump in manual mode and looking for leaks between the pump and its auto-coupling foot. If there is no leak, the pump is in its correct work position. If there is a leak, the pump must be moved, using its lift chain, until it is in its correct work position.



Pumps must never run dry. If that happens, stop their automation immediately!

MAINTENANCE

If there are no faults, we recommend performing visual and functional inspections at the following intervals:

- **pumping stations for industrial and public buildings – after every 3 months**
- **pumping stations in residential areas – after every 6 months**

The following maintenance procedure is recommended at least once per year:

1. Lift the pumps up along their guide rails, using their lift chains; then wash the pumps with a pressure jet and assess their condition.
2. Inspect the functioning of the valves inside the pumping station. Close and open the valves once.
3. Clean the inside of check valves from the collected debris and sediments. To do so, close the valves and open the backflow valve's cover.
4. Clean the pumping station's inner walls and bottom from sediments, using a pressure jet. Depending on the sediments collecting in the pumping station, the cleaning interval may be shorter or longer.
5. After completing the maintenance works above, lower the pumps along their guide rails to their auto-coupling feet again and check their functioning in operation conditions. Use the prescribed stainless steel lift chains for lifting and lowering the pumps.
6. Clean the float switches and the level sensor from sediments; visually inspect the condition of the pumps' power cables and equipotential connections of the pumping station's metal structures (ladder, etc.).
7. Repair or replace faulty elements!

As a rule, the pumping station's tank cylinder and internal structures do not need any further maintenance.

Pump maintenance must follow the manufacturer's instructions (technical passport). If the pumps are working below their stated productivity or emit noises that were not heard when the pumps were new, we recommend taking steps to eliminate the faults in order to prevent the pumps from possibly becoming unusable in the future. Contact a company providing pump maintenance services.

SAFETY

1. The employer of the pumping station's maintenance personnel must instruct the maintenance employees about electrical hazards and toxic exhaust gases and must provide them with necessary protective equipment.
2. Before starting maintenance of the pumping station, switch off the pumps at the control cabinet!
3. Before entering the pumping station, the pumping station must be ventilated for at least 5 minutes!
4. Only one person at a time may stand on the pumping stations service ladder and a single person must not carry along any items that are not lightweight and easy to use.
5. Do not use an ordinary pump for pumping oil, gasoline or other liquid presenting an explosion risk. An explosion-safe pump may be used in an explosive environment, but only with a temperature sensor.
6. It is strictly prohibited to perform any works inside the pumping station alone!
7. Close all inflows into the pumping station for the duration of maintenance works!
8. Before commissioning the pumping station, properly qualified personnel must verify that all applicable safety regulations are fulfilled. The earthing device, the neutral line and the equipotential connections must comply with regulations for electrical installations and must be inspected by qualified personnel.
9. If the pump has a plug connection, its earthed power outlet must be installed above the water level. The power cable of no-plug pumps must be connected by a qualified specialist.
10. If safety requirements are ignored, no damage claims will be accepted.

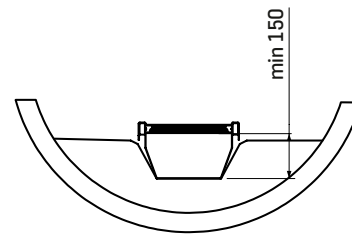
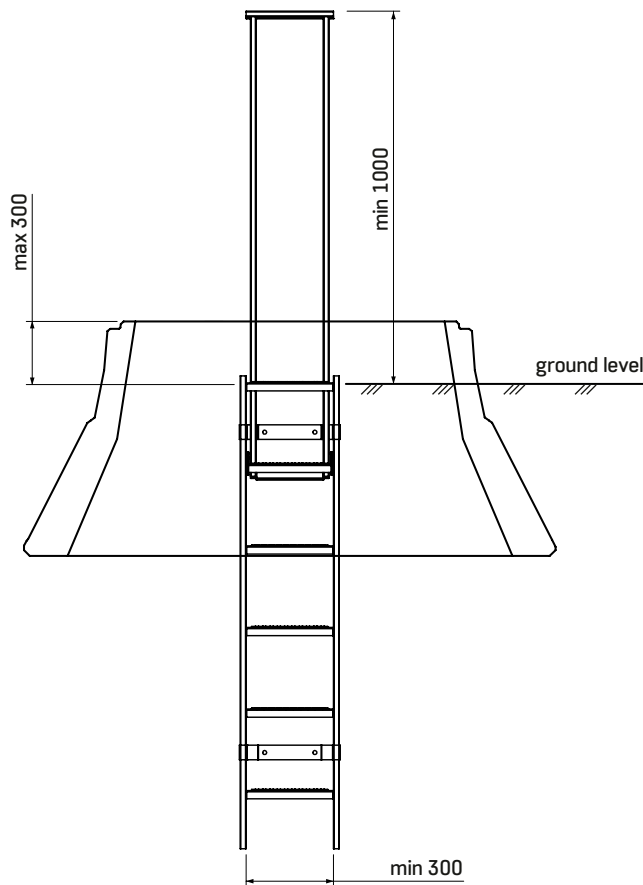

Requirements of Standard EN14396

The pumping station is serviced by people and needs to be entered from time to time, so special attention must be paid to safety. The requirements for ladders and handrails must be strictly observed. These are defined in the European Union standard EN14396.

WARRANTY

Innovative Water Systems undertakes the responsibility for the equipment's properties and for elimination of shortcomings becoming apparent during the equipment's use. The warranty terms stem from the legislation of the Republic of Estonia, and the warranty is first and foremost based on the manufacturers' warranties as long as they do not conflict with the laws of the Republic of Estonia. The warranty includes shortcomings of the equipment's or its individual elements' manufacture, materials or design.

1. General terms of warranty

1.1. The warranty is valid for 2 years i.e. 24 months in case of the product's purposeful use.

1.2. The warranty period starts from the product's handover date.

2. Warranty's validity terms

2.1. The prerequisite is the regulations in force and the installation and operation manuals required to be followed upon installation, use and maintenance of the equipment. The warranty will be valid if the equipment has been maintained regularly and used according to the manufacturer's instructions.

2.2. If the fault's identification requires that the equipment be dug out, this must be done in the presence of the manufacturer's representative.

2.3 The warranty does not include damage caused to third parties because of a faulty product; it also does not include loss of revenue or any other similar loss.

2.4. In case of a fault becoming apparent, the equipment shall be repaired, not replaced as a whole.

3. The warranty does not include:

- 3.1. training for installation, maintenance and use of the equipment;
- 3.2. repairs of transport damage and other mechanical damage (caused by vandalism, lightning, fire, etc.).

The warranty does not cover shortcomings caused by insufficient maintenance, incorrect installation and repairs, or normal wear. The warranty is also void if the equipment has been reconstructed.

